

- NOTES;
1. ALL STEEL TO AS 3678 GR250
 2. x2 SECURITY BOLT M10 x 35 LONG
 3. GMS (STEEL) ACCESS COVER TO AS3996 : 2019 CLASS D
 4. CONCRETE TO 40 MPa
 5. FINISH HOT DIP GALV
 6. REMOVE ALL SHARP EDGES
 7. LOCKING AND UNLOCKING BY SECURITY KEY ONLY 14460
 8. USED INCONJUNCTION WITH 14479 PE BATTERY BOX

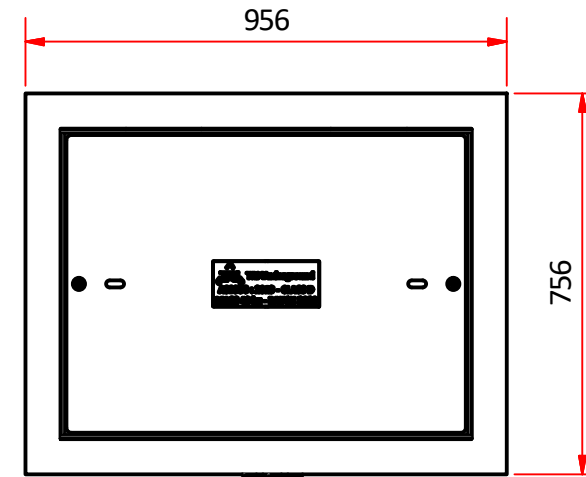

TOP VIEW (1:15)

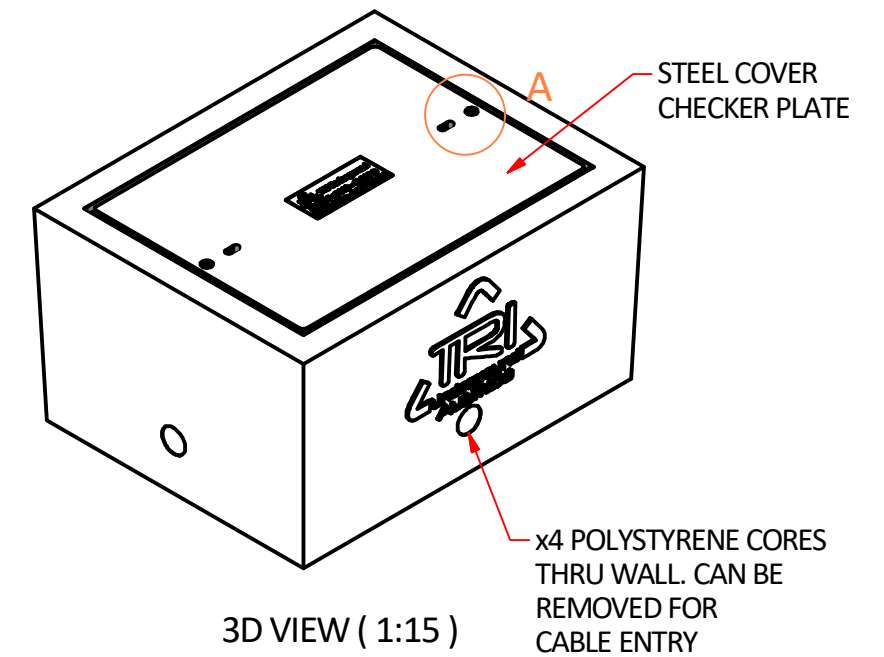
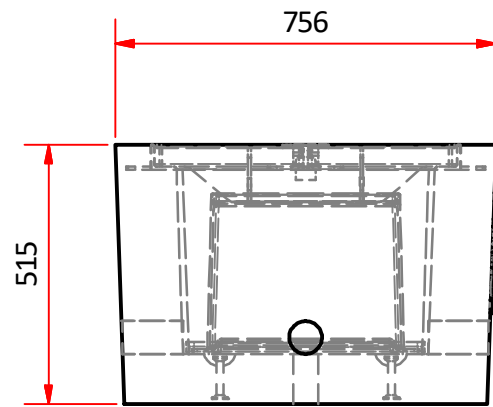

END VIEW (1:15)

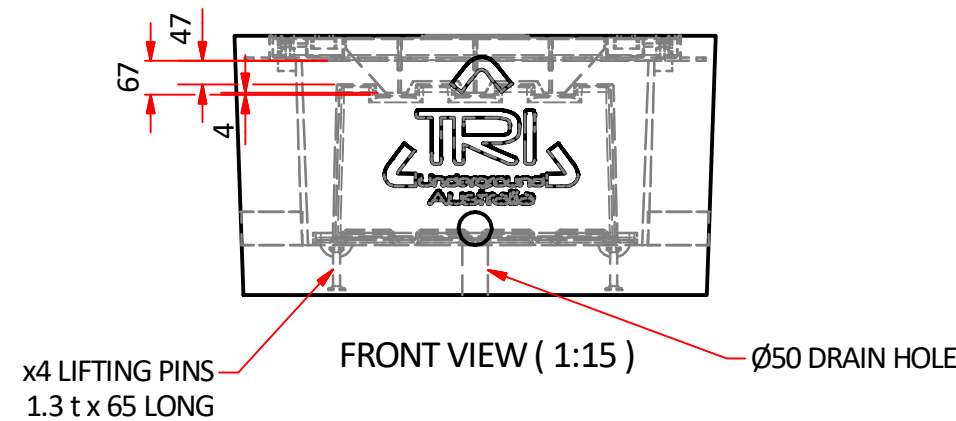

FRONT VIEW (1:15)

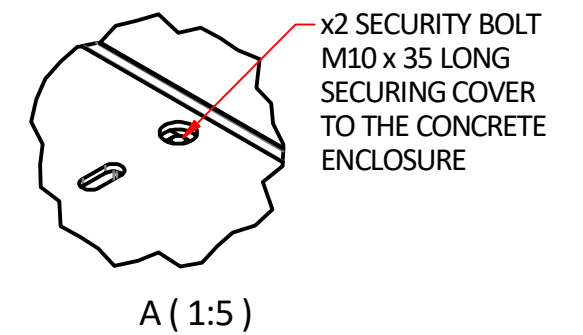

- General Notes;
1. All dimensions are in mm
 2. Tolerance on all dimensions ± 3 mm unless stated otherwise

Copyright: TRI Underground Australia Pty Ltd

This instruction and all the information herein is the property of TRI Underground PTY LTD. It must not be copied, made public or used directly or indirectly, including manufacture of the product shown herein, without written approval. This instruction is loaned subject to these conditions and subject to return on demand.

Commercial in confidence

	Material CONCRETE	Designed by IMD	Checked by HL	Approved by HA	Date 23/03/2022	Date 22/01/2022
	Weight APPROX. 600 kg	TRI Underground Australia			Title CONCRETE PIT SUITS PE BATTERY BOX	
	Finish OFF MOULD				Dwg No. 14471	Edition A